

Differential Pressure Gauges Stainless Steel Series Model 736.51, with Capsule Element for Electrical Accessories

WIKA Data Sheet PM 07.08

Applications

- Differential pressure measurement at measuring points with very low differential pressures, for transparent, gaseous, dry, clean, oil and grease free media, also in aggressive ambience
- Especially for fitting with alarm contacts or transmitters
- ⊕ media chamber also suitable for corrosive media
- Filter monitoring in ventilation and heating systems or in overpressure and clean rooms
- Differential pressure controlled monitoring of ventilator and blast pressures

Special Features

- Differential pressure measuring ranges from 0 ... 2.5 mbar
- As a standard zero adjustment from the front
- Ingress protection IP 66
- Case of stainless steel



Differential Pressure Gauge Model 736.51

Description

Design

high overpressure safety,
media chamber protected against unauthorised intervention, zero adjustment under pressure load
WIKA trade pattern DT - GM 86 08 176

Nominal size in mm

100, 160

Accuracy class

1.6

Scale ranges

0 ... 2.5 to 0 ... 160 mbar
or all other equivalent vacuum or combined pressure and vacuum ranges

Pressure limitation

Steady: full scale value
Fluctuating: 0.9 x full scale value

Differential overpressure safety

⊕-side: 200 mbar

Max. working pressure (static pressure)

200 mbar

Operating temperature

Ambient: -20 ... +60 °C
Medium: +60 °C maximum

Ingress protection

IP 66 per EN 60 529 / IEC 529

Illustration of the principle

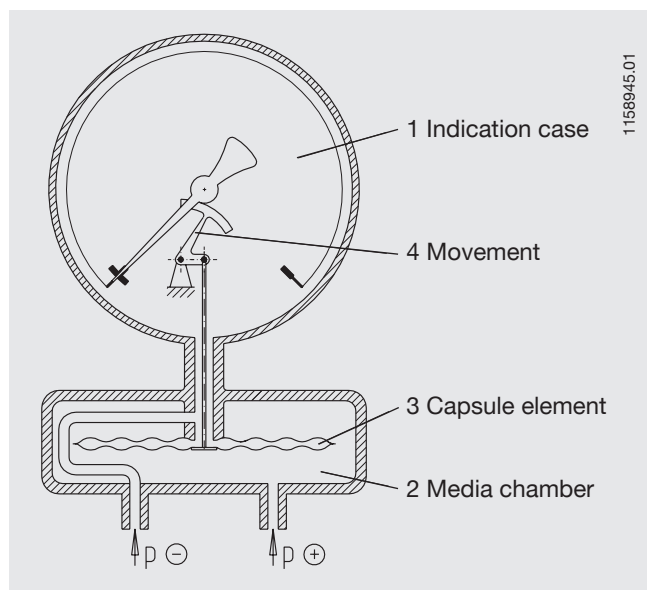

Design and operating principle

- Pressure-sealed indication case (1) with capsule pressure element in pressure-sealed media chamber (2).
- Capsule element (3) is pressurised inside and outside
 - ⊕ pressure is retained in media chamber (2),
 - ⊖ pressure is retained in capsule element (3) and indication case (1)
- Pressure differential between ⊕- and ⊖-side deflects the capsule element
- The deflection is transmitted via the movement (4) and indicated

Note:

Electrical accessories include plastic components and copper alloys. They are incorporated in the pressure-sealed indication case (1), i.e. they are wetted! Therefore we recommend a feasibility test (particularly with flammable, explosive gases).

Standard version

Process connection (wetted)

Stainless steel 1.4571, 2 x G ½ B male, 22mm flats

Pressure element (wetted)

Stainless steel 1.4571

Measuring cell (wetted)

Stainless steel 1.4571

Movement (wetted)

Stainless steel

Dial (wetted)

Aluminium, white, black lettering

Pointer (wetted)

Aluminium, black

Zero adjustment (wetted)

via adjusting device at case circumference, stainless steel

Case (wetted)

Stainless steel, with pressure relief of PUR (Lupolene)

Window (wetted)

Laminated safety glass

Sealings (wetted)

PTFE and NBR (buna rubber)

Bezel ring (wetted)

Cam ring (bayonet type), stainless steel

Mounting

according to affixed symbols ⊕ and ⊖,
⊕ high pressure, ⊖ low pressure

Mounting by means of:

- Rigid tailpipes
- Panel or surface mounting flange (option)
- Instrument mounting brackets for wall or pipe mounting (option)

Options

- Other process connection
- Panel or surface mounting flange (observe media chamber!)
- Alarm contacts (plastics, Cu-alloy), (see data sheet AC 08.01) - wetted ¹⁾
- Transmitters (plastics, Cu-alloy), (see data sheet AC 08.02) - wetted ¹⁾
- Instrument mounting brackets for wall or pipe mounting (see data sheet AC 09.07)
- Pressure equalising valve (see data sheet AC 09.11) - wetted
- ⊖-side overpressure safe up to 200 mbar
- Max. total pressure applied (static pressure) > 200 mbar ¹⁾
- Indication accuracy class 1.0 ¹⁾

1) After feasibility test

Dimensions in mm

Lower mount (LM)

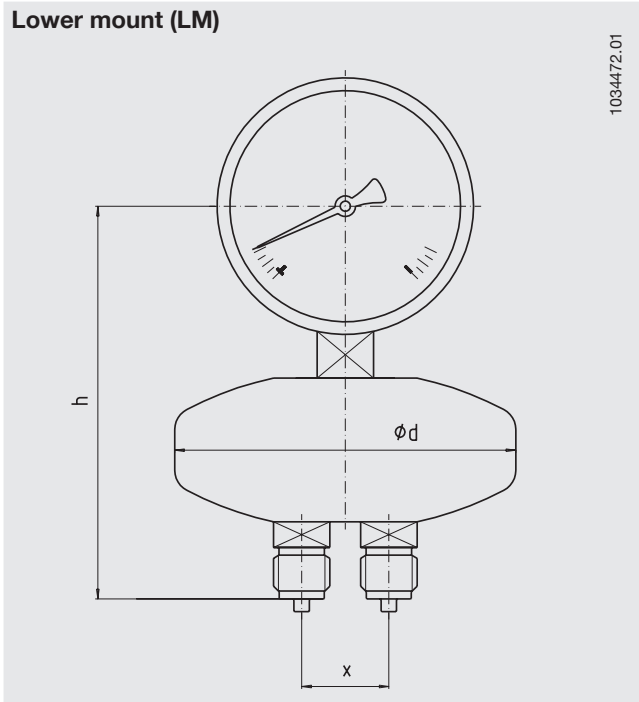

Lower mount (LM)

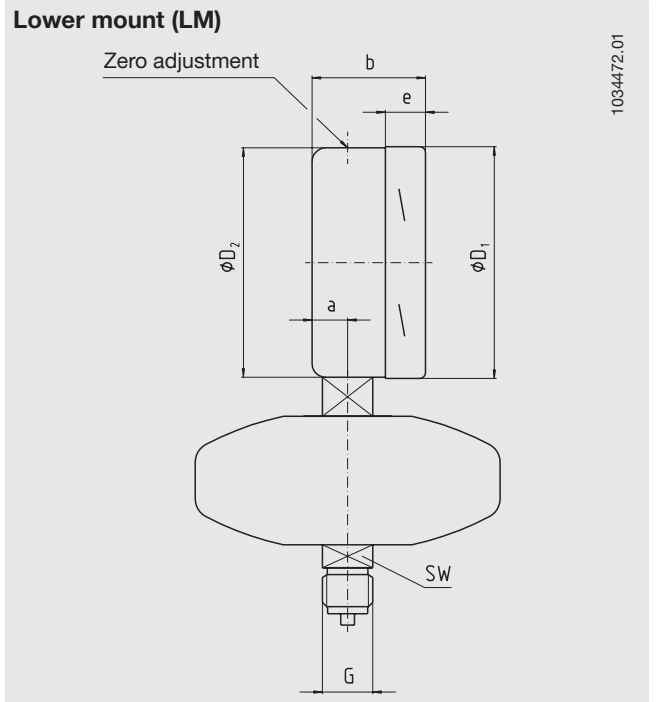

NS	Dimensions in mm										Weight in kg
	a	b	D1	D2	d	e	G	$h \pm 1$	X	SW	
100	15.5	49.5	101	99	133	17.5	G ½ B	170	37	22	1.70
160	15.5	49.5	161	159	133	17.5	G ½ B	200	37	22	2.20

Process connection per EN 837-1 / 7.3

Ordering information

Model / Nominal size / Scale range / Scale layout (linear pressure or square root incrementation) / Max. working pressure (static pressure) ... bar / Connection size / Options

Modifications may take place and materials specified may be replaced by others without prior notice.
Specifications and dimensions given in this leaflet represent the state of engineering at the time of printing.



WIKA Alexander Wiegand GmbH & Co. KG
Alexander-Wiegand-Straße 30
63911 Klingenberg/Germany
Tel. (+49) 9372/132-0
Fax (+49) 9372/132-406
E-mail info@wika.de
www.wika.de